

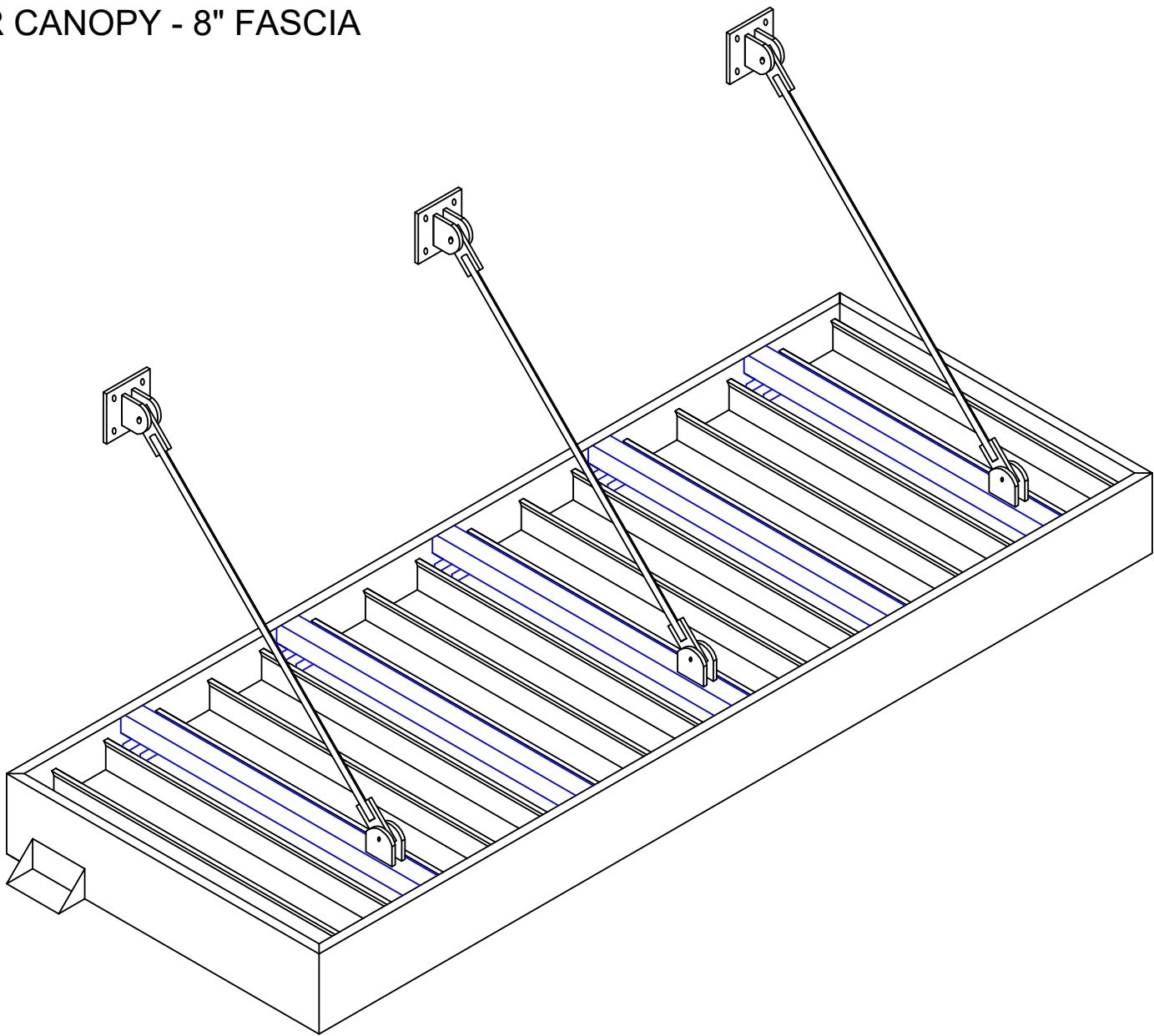

COOL PLANET STANDARD ARCHITECTURAL CANOPY

- FLAT MARQUEE STYLE

- PAN & GUTTER CANOPY - 8" FASCIA



 340 S. Mitthoeffer Rd. • Indianapolis, IN 46229 P (317) 927-9000 • F (317) 927-9003 www.coolplanetawnings.com	Cool Planet Awning Company	
	Pan & Gutter Canopy	
DRAWN BY	APPROVED BY	DATE
DRAWING NO.	REVISION DATE	SCALE 3/8"=1' SHEET C1

1/C2

TRANSVERSE SECTION

Scale: 1"=1'

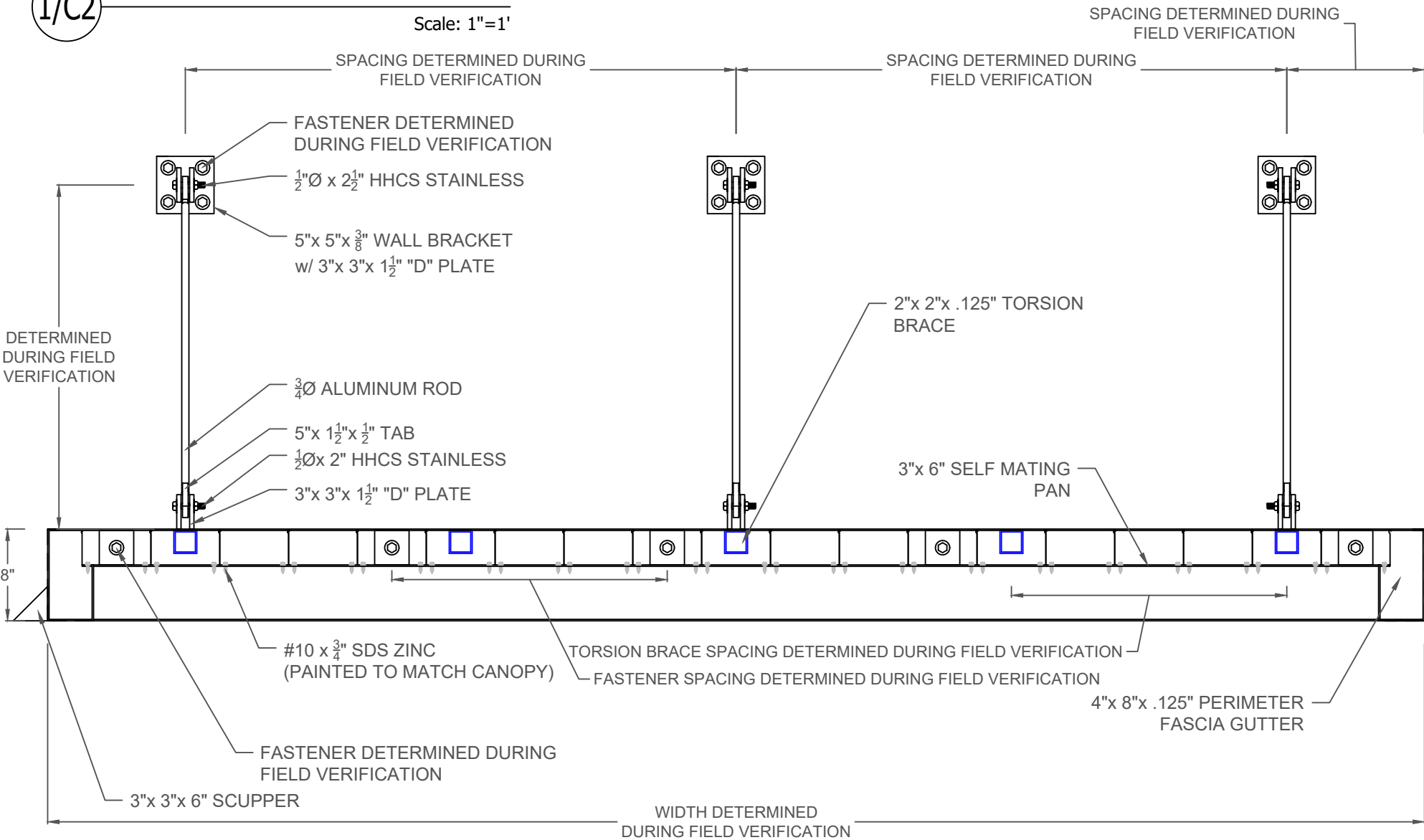

340 S. Mitthoeffer Rd. • Indianapolis, IN 46229
 P (317) 927-9000 • F (317) 927-9003
 www.coolplanetawnings.com

Cool Planet Awning Company

Pan & Gutter Canopy

DRAWN BY	APPROVED BY	DATE
REVISION DATE	SCALE	SHEET
	noted	C2

2/C3

PLAN VIEW

Scale: 1"=1'

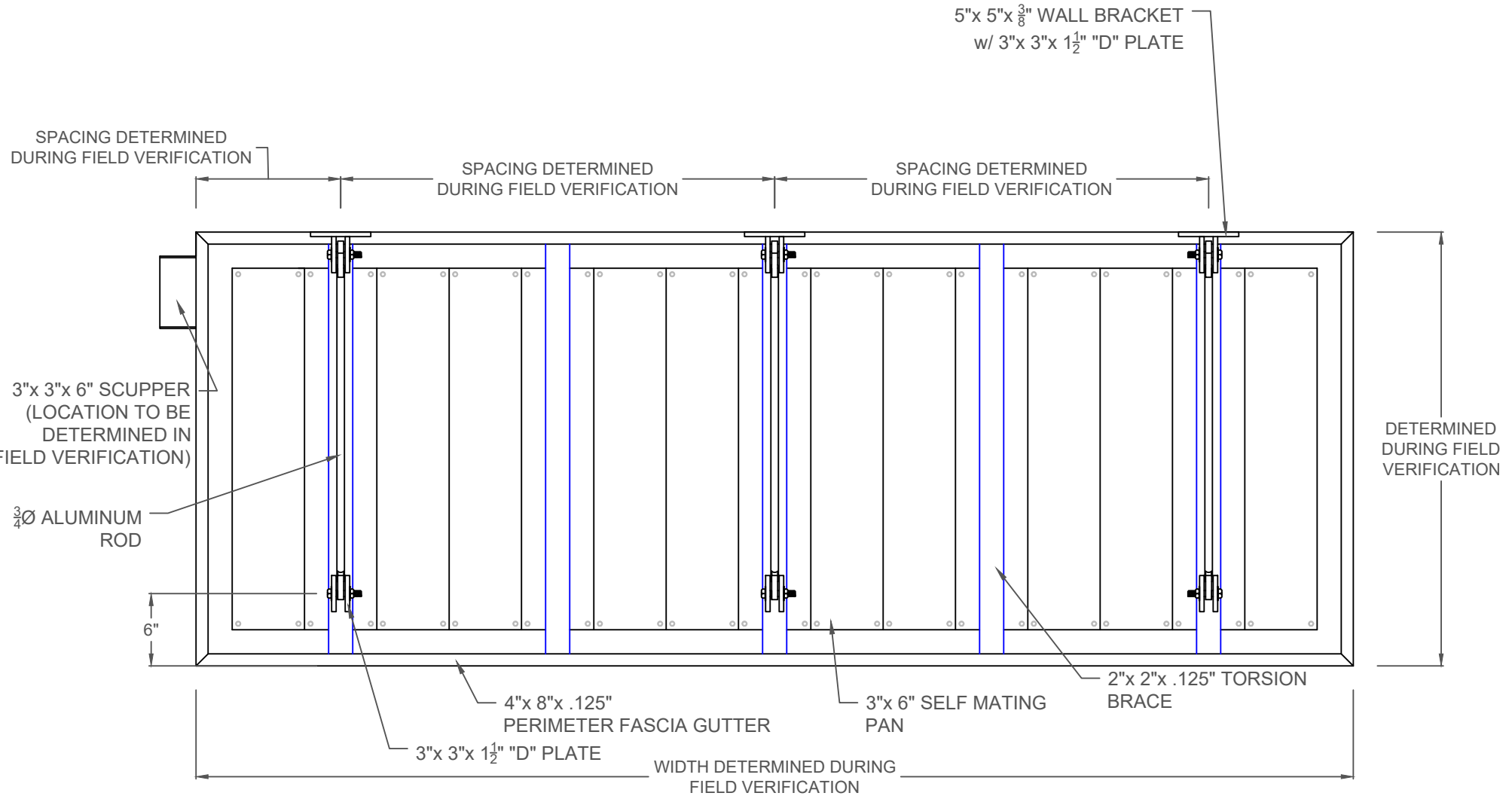

COOL PLANET
AWNING COMPANY

340 S. Mitthoeffer Rd. • Indianapolis, IN 46229
P (317) 927-9000 • F (317) 927-9003
www.coolplanetawnings.com

Cool Planet Awning Company

Pan & Gutter Canopy

DRAWN BY	APPROVED BY	DATE
REVISION DATE	SCALE	SHEET
	noted	C3

3/C4

SECTION - RETURN ARM

Scale: 1-1/4"=1'

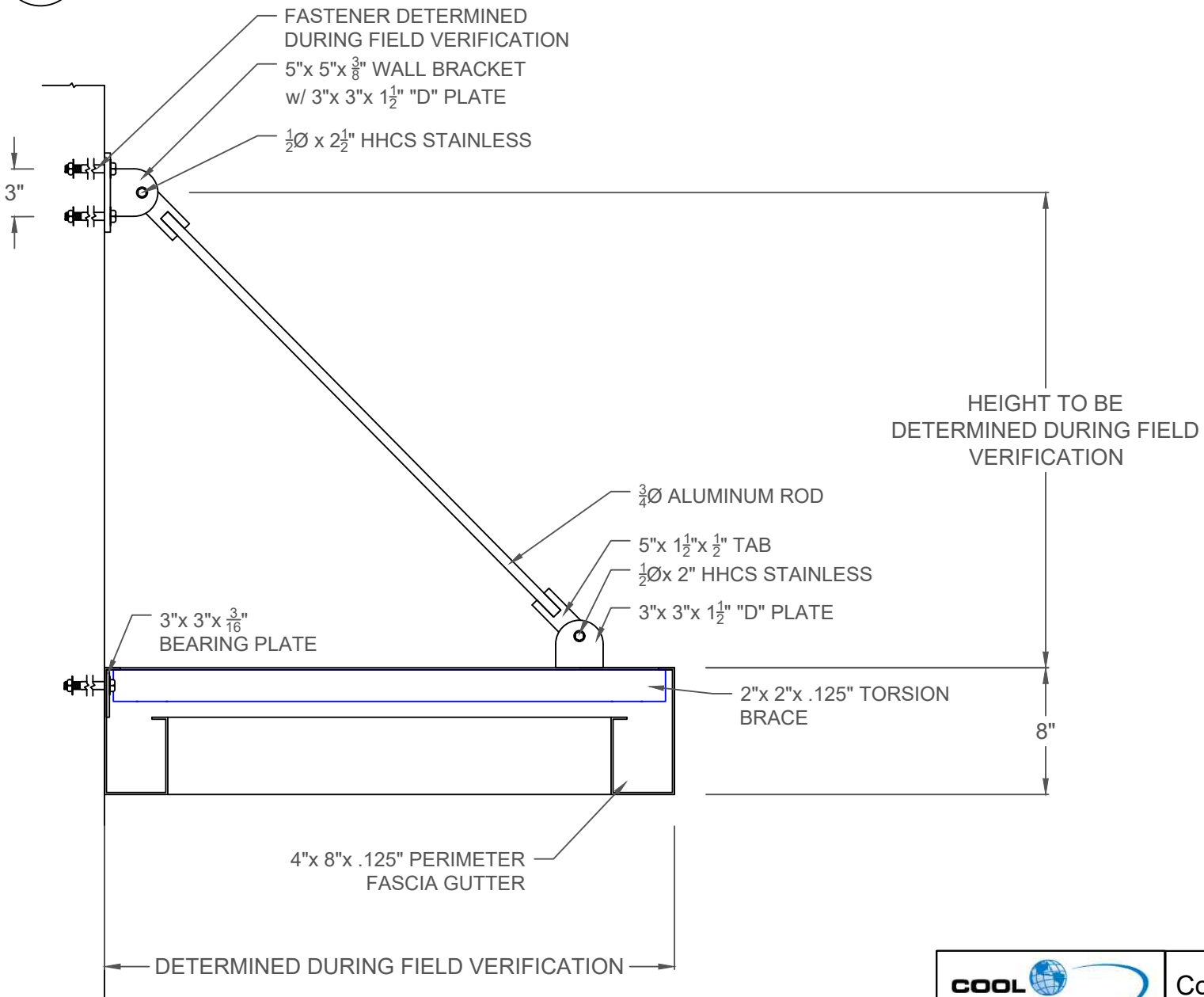

Cool Planet Awning Company

Pan & Gutter Canopy

340 S. Mitthoeffer Rd. • Indianapolis, IN 46229
 P (317) 927-9000 • F (317) 927-9003
 www.coolplanetawnings.com

DRAWING NO.	REVISION DATE	SCALE	SHEET
		noted	C4

4/C5

SECTION - PANS

Scale: 2"=1'

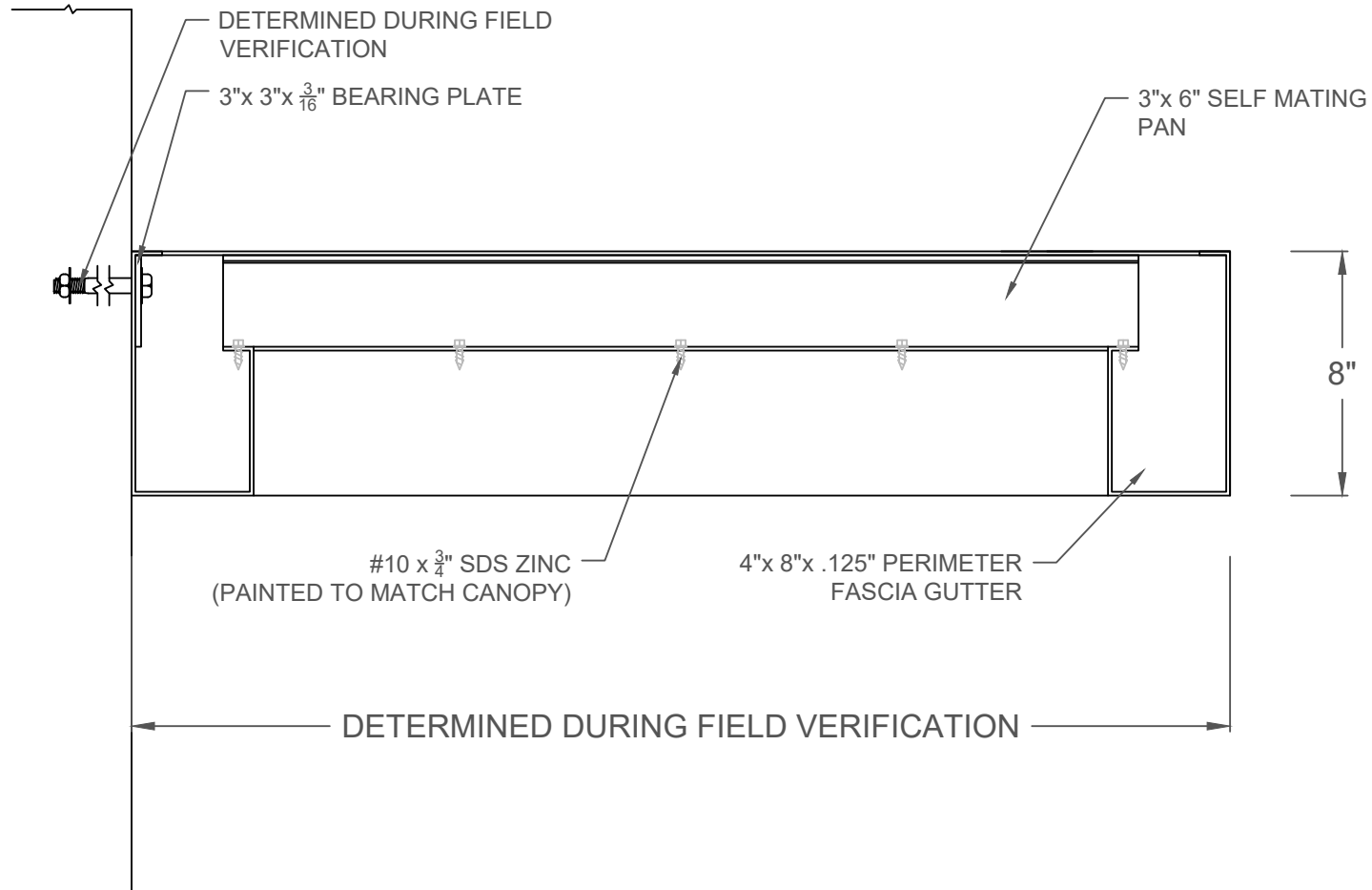



 <p>COOL PLANET AWNING COMPANY</p>	Cool Planet Awning Company		
	Pan & Gutter Canopy		
340 S. Mitthoeffer Rd. • Indianapolis, IN 46229 P (317) 927-9000 • F (317) 927-9003 www.coolplanetawnings.com	DRAWN BY	APPROVED BY	DATE
DRAWING NO.	REVISION DATE	SCALE	SHEET
		noted	C5

5/C6

RETURN ARM & BRACKET

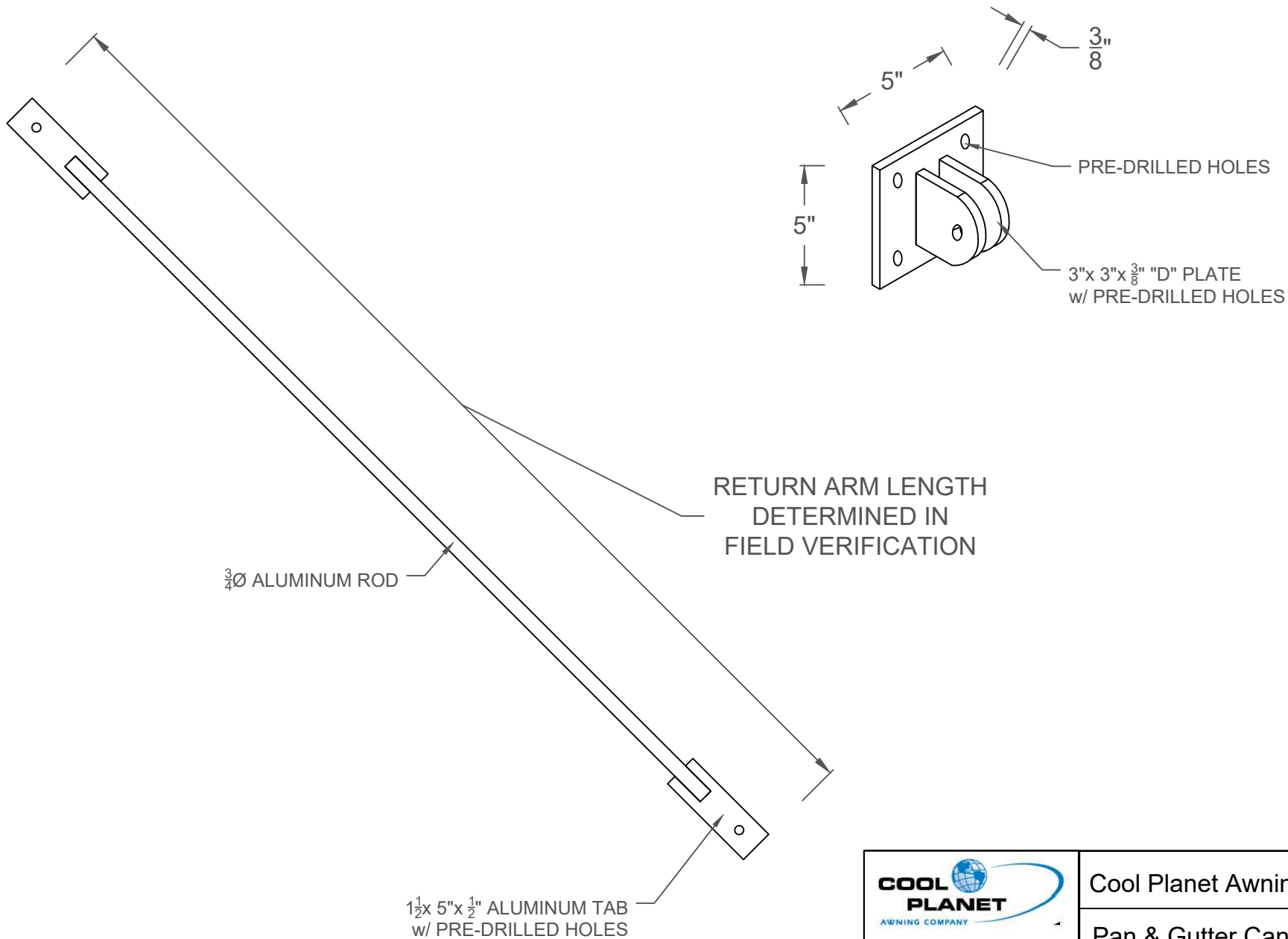
Scale: 2"=1'



	Cool Planet Awning Company		
	Pan & Gutter Canopy		
340 S. Mitthoeffer Rd. • Indianapolis, IN 46229 P (317) 927-9000 • F (317) 927-9003 www.coolplanetawnings.com	DRAWN BY	APPROVED BY	DATE
DRAWING NO.	REVISION DATE	SCALE	SHEET
		noted	C6

6/C7

MATERIAL LIST

Scale: 3"=1'

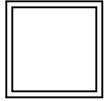

2" x 2" x .125" ALUMINUM TUBE - 6063-T52



3" x 6" x .065" SELF MATING CANOPY ROOF PAN - 6063-T6

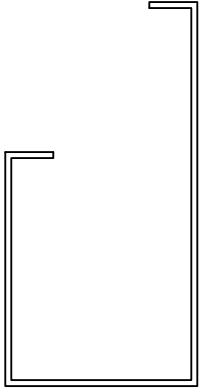

4" x 8" x .125" ALUMINUM GUTTER FASCIA - 6063-T6

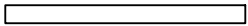

3/8" x 5" x ALUMINUM BAR - 6061-T6511



1/2" x 5" x . ALUMINUM BAR - 6061-T6511



3/4Ø ALUMINUM ROD - 6061-T6511



#10 x 3/4" SELF DRILLING TEK SCREW - ZINC (PAINTED TO MATCH CANOPY COLOR)

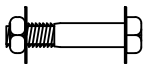

1/2Ø x 2-1/2" HEX HEAD CAP SCREW - STAINLESS

	Cool Planet Awning Company		
	Pan & Gutter Canopy		
340 S. Mitthoeffer Rd. • Indianapolis, IN 46229 P (317) 927-9000 • F (317) 927-9003 www.coolplanetawnings.com	DRAWN BY	APPROVED BY	DATE
DRAWING NO.	REVISION DATE	SCALE noted	SHEET C7

4"x12"x.125" GUTTER

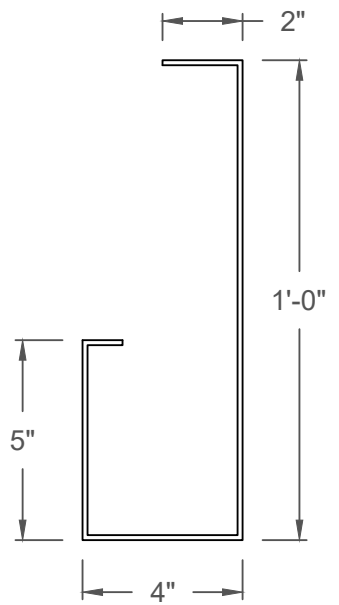

1"x4"x.125" GUTTER FASCIA EXTENDER

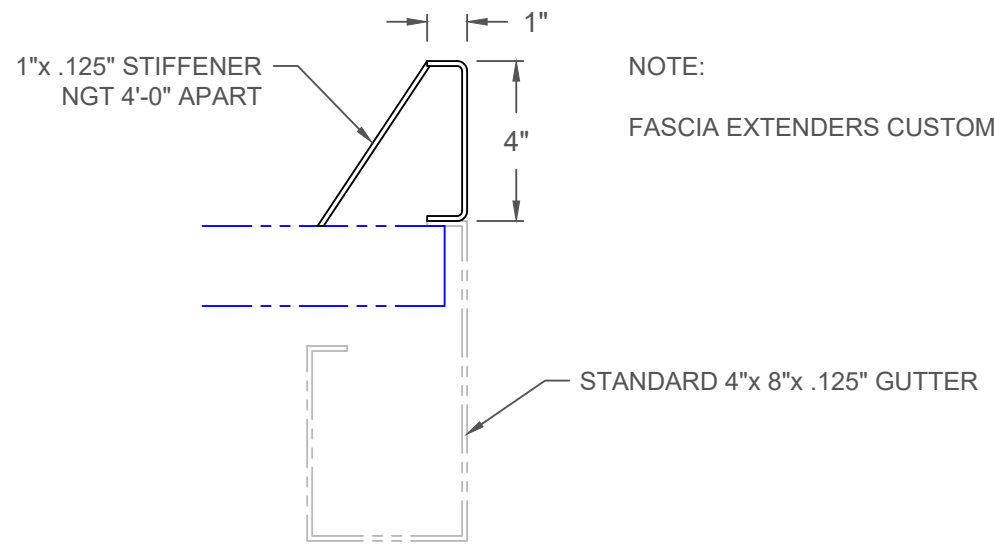

2"x8"x.125" PERIMETER "C" CHANNEL

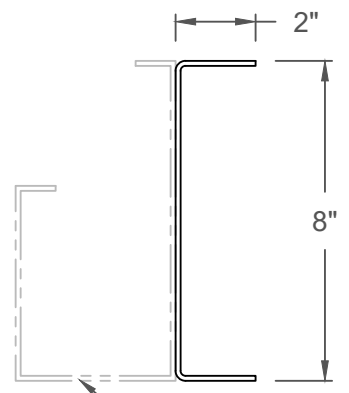

NOTE:
PERIMETER "C" CHANNEL
CUSTOM BENT PER JOB SPECS.

STANDARD 4"x 8"x .125" GUTTER

	Cool Planet Awning Company		
	Pan & Gutter Canopy		
340 S. Mitthoeffer Rd. • Indianapolis, IN 46229 P (317) 927-9000 • F (317) 927-9003 www.coolplanetawnings.com	DRAWN BY	APPROVED BY	DATE
DRAWING NO.	REVISION DATE	SCALE	SHEET
		noted	C8

DECKING ADD-ONS

Scale: 3"=1'

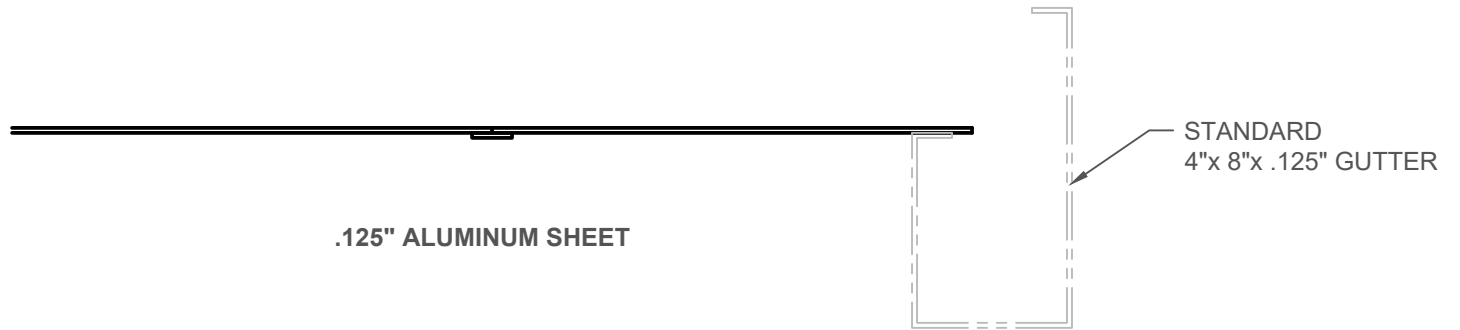
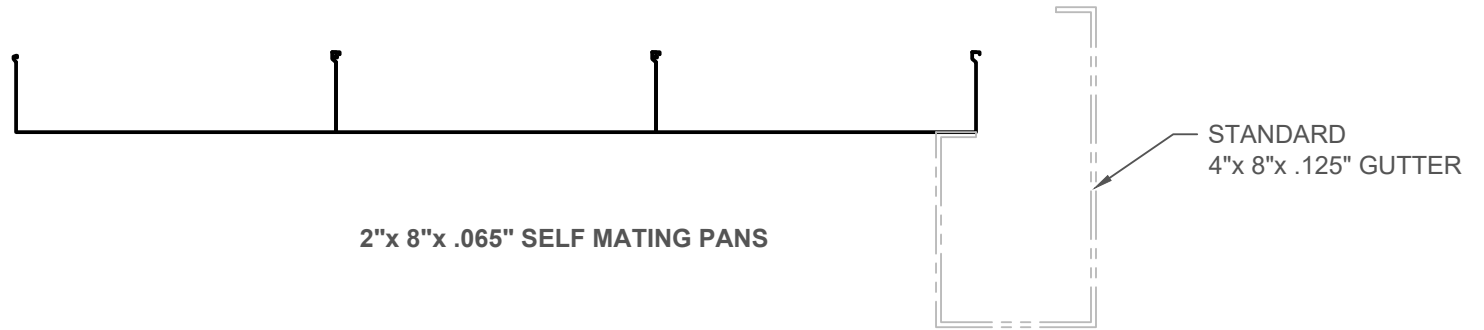
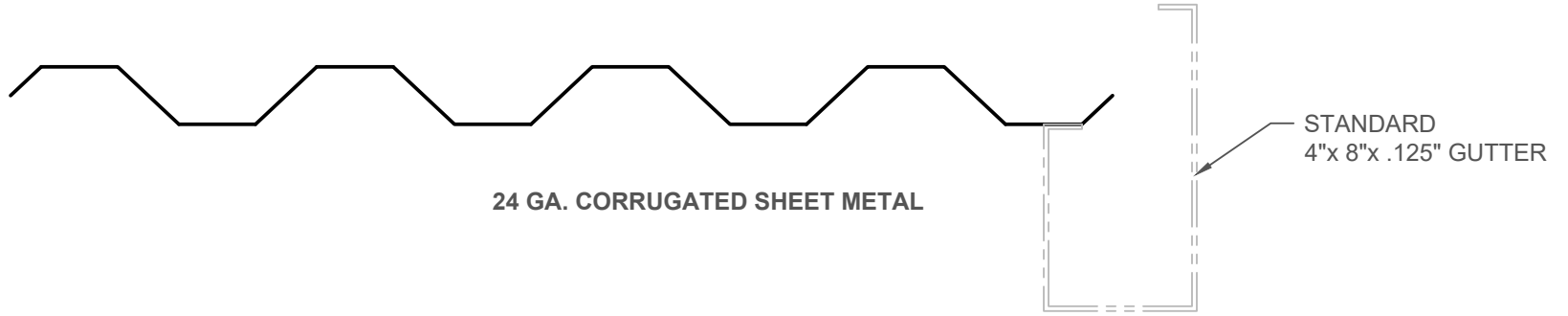

340 S. Mitthoeffer Rd. • Indianapolis, IN 46229
 P (317) 927-9000 • F (317) 927-9003
 www.coolplanetawnings.com

Cool Planet Awning Company

Pan & Gutter Canopy

DRAWN BY	APPROVED BY	DATE
----------	-------------	------

DRAWING NO.	REVISION DATE	SCALE	SHEET
		noted	C9

DRAINAGE ADD-ONS

Scale: 3"=1'

DOWNSPOUT

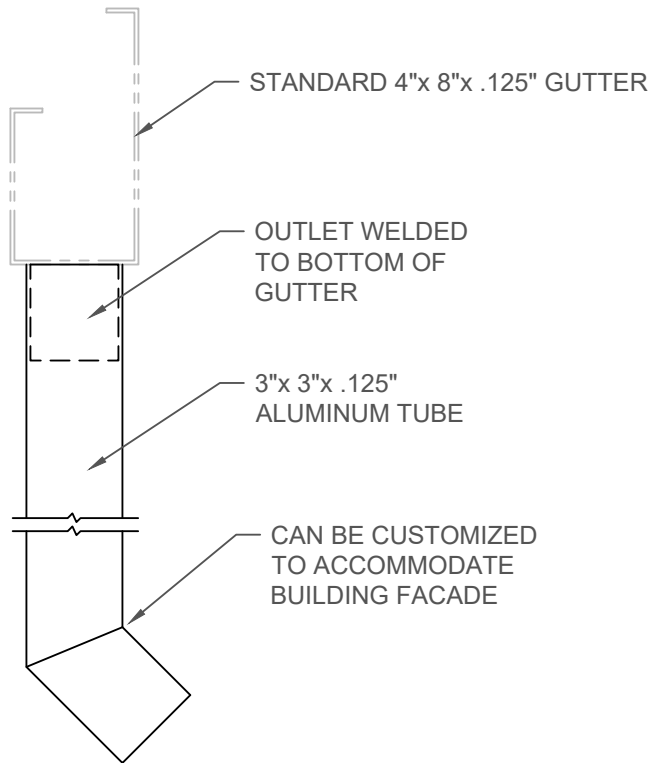

DRAINAGE THROUGH UPRIGHT

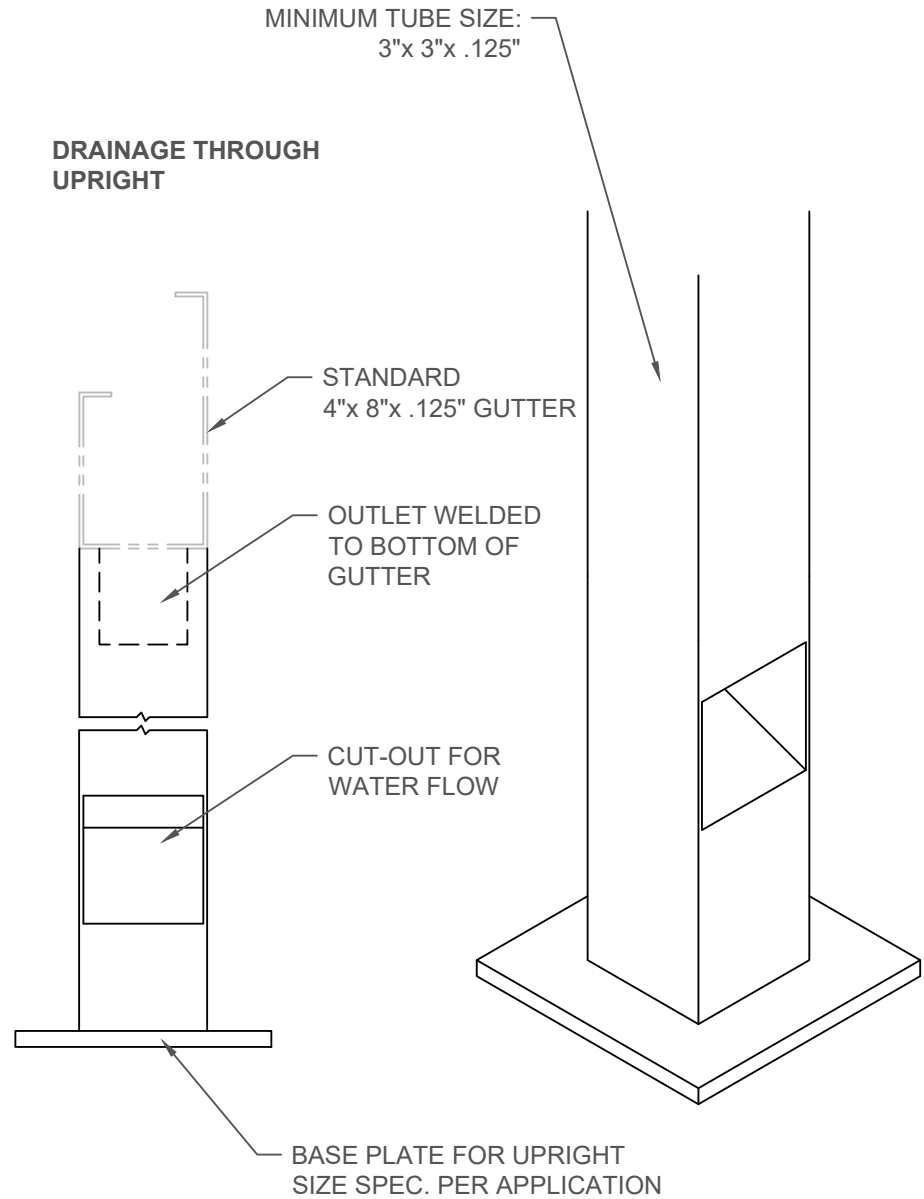

	Cool Planet Awning Company		
	Pan & Gutter Canopy		
340 S. Mitthoeffer Rd. • Indianapolis, IN 46229 P (317) 927-9000 • F (317) 927-9003 www.coolplanetawnings.com	DRAWN BY	APPROVED BY	DATE
DRAWING NO.	REVISION DATE	SCALE	SHEET
		noted	C9